

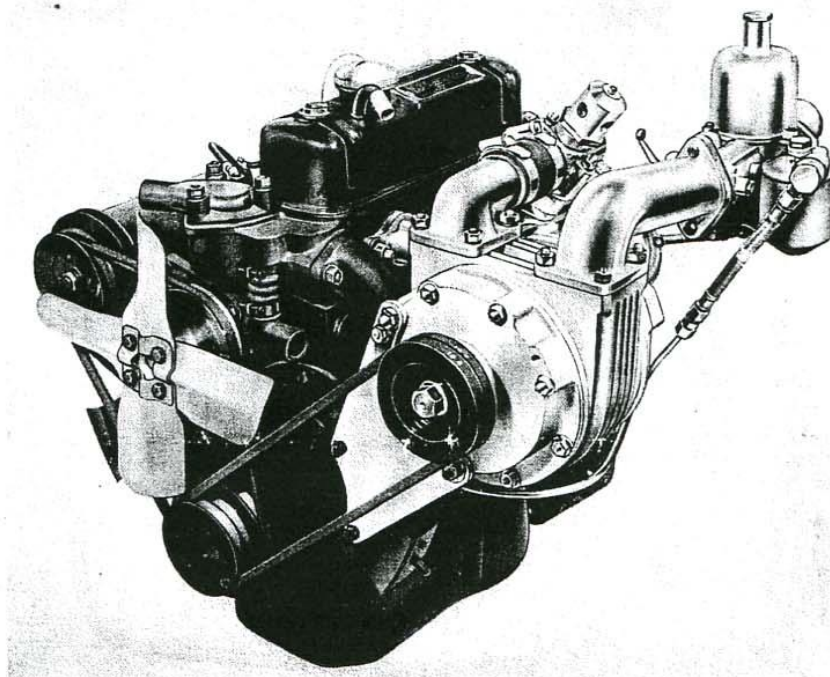

## **SUPERCHARGER**



# **FITTING INSTRUCTIONS**

## **“A” SERIES ENGINE**

**AS FITTED TO THE AUSTIN HEALEY SPRITE  
AUSTIN A35 MORRIS MINOR 1,000 AUSTIN A40**

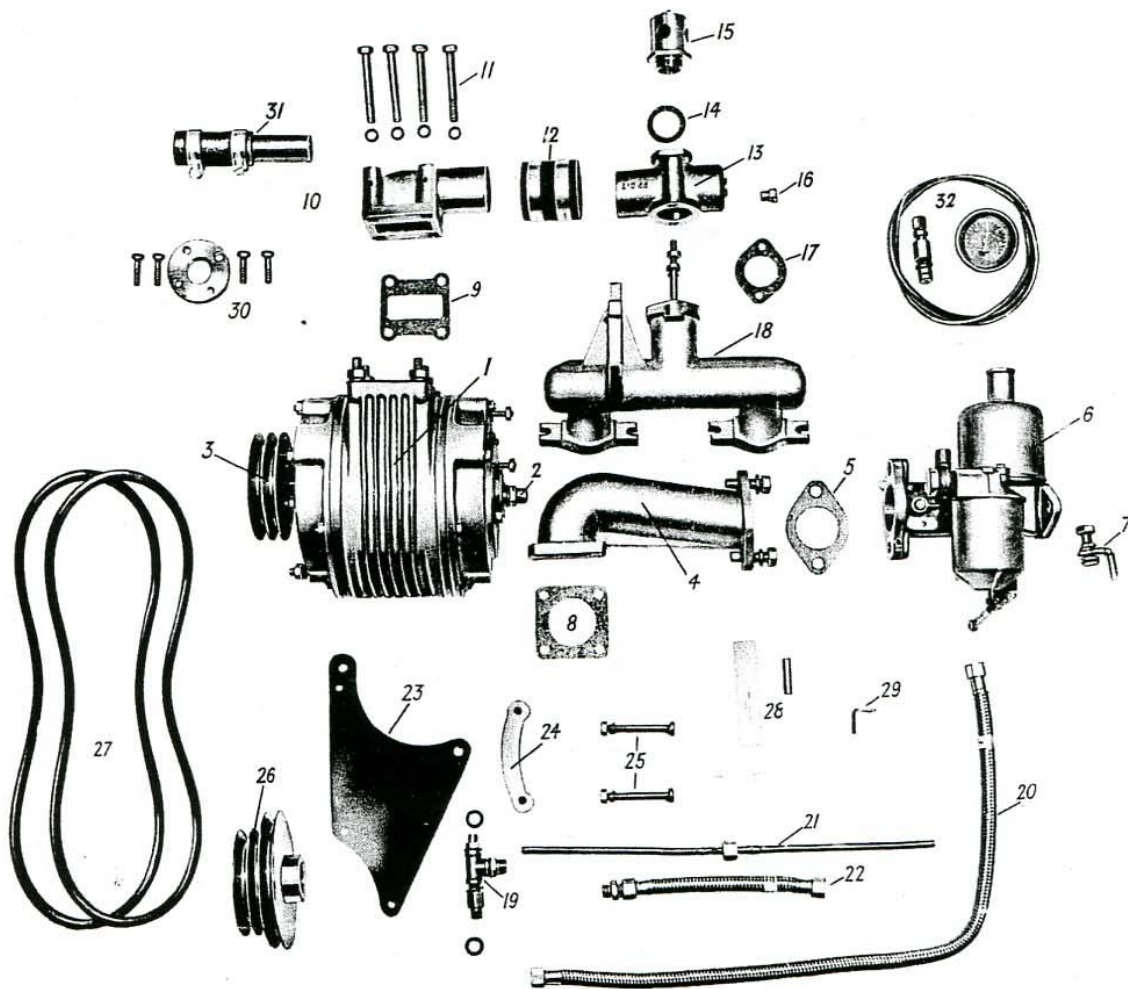

1. C. 75 B Supercharger.
2. Lubricator.
3. Supercharger Pulley.
4. Carburettor Pipe (Shorter Pipe for Minor 1000 and A/40)
5. Carburettor Gasket.
6. 1½ S. U. Carburettor Type H4 32 M.M. Solex for A/35.
7. Outer Cable Stop Bracket.
8. Inlet Port Gasket.
9. Outlet Port Gasket.
10. Outlet Pipe.
11. Set Bolt and Washer 5/16" B.S.F.
12. Rubber Hose and Clips.
13. Relief Valve Pipe.
14. Relief Valve Gasket.
15. Relief Valve.
16. Brass Plug (Boost Gauge Tapping).
17. Relief Valve Pipe Gasket.
18. Induction Manifold.
19. "T" Piece complete with Union and Washers.
20. Oil Supply Pipe 24" long.
21. Fuel pipe with Nut and Olives.
22. Flexible Pipe with Union (Carburettor Connection not supplied for Minor 1000).
23. Front Plate.
24. Front Plate Distance Piece.
25. UNF Bolts with Nuts and Washers ¼"x 2¼"
26. Crankshaft Pulley.
27. Belts.
28. Spare Metering Pin and Sachet.
29. Throttle Return Spring Bracket.
30. Fan Distance Piece and Set Bolts.
31. Bottom Water Pipe Extension with Hose and Clips (2 Bends and Hose Supplied for Minor 1000).
32. Boost Gauge complete with Nylon Tube and Pipe Connections (OPTIONAL).

WHEN ORDERING SPARES PLEASE QUOTE REFERENCE NUMBER  
AND DESCRIPTION.

## INTRODUCTION

The design of the Supercharger set for the "A" Series Engine is such that the work may be confidently carried out by any competent garage mechanic or owner driver, and necessitates no modification to the engine or chassis. Fitting is simplified by reading through these instructions before starting work.

The Supercharger is mounted on the manifold side of the engine with the ports facing upwards, and is driven by twin Vee Belts from the front end of the crankshaft.

During the installation, care should be taken to retain all nuts and washers removed and to avoid damaging any packing as some of these are used again with the Supercharger set.

## PRELIMINARY INSTRUCTIONS

- 1 Drain radiator.
- 2 Disconnect carburettor controls and petrol pipe and vacuum ignition control pipe.
- 3 Remove induction manifold and carburettor complete. With all sets except Sprite a blanking plate and set pins are supplied to blank off the exhaust manifold hot spot.
- 4 Remove radiator.
- 5 Slacken dynamo belt and remove crankshaft pulley and fan.
- 6 Disconnect petrol pipe from pump.
- 7 Remove the two short bolts holding the timing case cover to the engine front plate. These screw into the latter and are the two which are clear of the engine block itself. The car is now ready for the Supercharger to be fitted.

## CRANKSHAFT PULLEY.

Fit new 3 groove crankshaft pulley, care should be exercised when fitting, as being made of cast iron, undue force could cause damage. With Austin Healey Sprite, it is necessary to raise the engine 3" at the front end. Whilst the engine is in this position it is advisable to slip all belts over their respective grooves.

## MOUNTING THE SUPERCHARGER

The Supercharger can now be positioned. Locate it by the new cast induction manifold which is already bolted to the Supercharger, to the Cylinder head. If care is taken the manifold and Supercharger can be fitted as one.

Place the aluminium distance piece between the timing case cover and the front plate and secure with the 2 1/4" UNF. bolts supplied. These screw into the existing tapped holes and protrude to the rear of the engine front plate where they are finally locked by using the nuts and spring washers supplied.

The Supercharger is now in position and all nuts and bolts and Jubilee clips may now be finally tightened including the locking nuts.

As the ignition characteristics of the Supercharged engine are so different from standard, it is desirable to dispense with the vacuum operated advance and retard. This is done by removing the small bore pipe which connects between carburettor and distributor.

## BELTS

Replace and adjust the dynamo belt and fit the Supercharger belts. These will be found tight but can be 'run on' to the Supercharger pulley, if the sparking plugs are removed and a spanner is applied to the Supercharger drive shaft nut. The best way, of course is to use the car starting handle to turn the engine, but on some models this is not provided in the car tool kit.

## FAN

Refit the fan using the aluminium distance piece to bring the fan clear of the Supercharger drive belts longer bolts are supplied to accommodate this.

## PETROL PIPE

Remove the existing petrol pipe from the pump and by using the copper pipe supplied, form a new one which will run from the pump under the Supercharger and terminate approximately 6 1/2" from the Carburettor. A flexible pipe is provided to connect the end of this copper pipe to the banjo union of the Carburettor. All the necessary pipe fittings are supplied except the pipe nut which secures pipe to pump, this must be removed from the previously removed standard fuel pipe.

## RADIATOR

Replace the radiator. Dependant on the type of car to which the Supercharger is fitted the bottom water pipe connections may have to be re-routed. Extension pipes are provided for this with hose and clips, except in the case of the A.40 when connection can be made in the usual way.

## LUBRICATION.

Unscrew from the Crankcase the oil pressure switch or pressure gauge connection and union. In place of this fit the special union and 'T' piece supplied. When tightened up, one branch of the 'T' should point towards the bulkhead. Into the other branch screw the pressure switch or gauge connections. Using the 24" flexible pipe connect one end to the 'T' and the other to the Union which is already screwed into the Supercharger lubricator this is positioned in the centre of the Supercharger rear end plate.

## CARBURETTOR

The carburettor is bolted to the carburettor pipe which is already assembled to the Supercharger. Use the cork or fibre gasket at the flange joint.

A separate leaflet is enclosed explaining the method of fitting choke and throttle controls.

## ROAD TESTING

It now remains to road test the car to obtain the correct carburettor and ignition settings, but read to the end of these instructions **FIRST.**

## SERVICING INSTRUCTIONS.

The Shorrock Supercharger is a precision mechanism, which is fully tested before despatch. Like any other machine, however, it requires running in and should be driven fairly gently for the first 250 miles. During this period, the maximum engine speed should not exceed 3,500 r.p.m.

## LUBRICATION.

It is essential that the engine oil be kept clean and free from sludge. Dirty or unsuitable oil will clog the lubricating passages and eventually lead to serious damage. The Supercharger is despatched with a 'B' pin in its lubricator. This should be satisfactory for initial running and quite likely permanently. As a guide there should be a slight amount of smoke from the exhaust on starting from cold, which should clear after a few minutes running. Should however, signs of pronounced over oiling arise (for instance clouds of exhaust smoke) then the lubrication pin should be replaced by the larger one 'A' supplied in a plastic capsule bolted to the Supercharger. If this spare pin is used, be sure to tighten down firmly the Supercharger nuts. Every 1000 miles the lubricator pin should be removed from the Supercharger, and the pin wiped with a soft rag, on no account should abrasives be used. To remove and replace the lubricator pin, proceed as follows.

Unscrew the pipe connection at the Supercharger whereupon the pin will be partially pushed out by the spring which is positioned underneath it. Insert a small screwdriver into the slotted end of the pin and draw it out. If the spring should come out with the pin remember that this should go in first when re-assembling.

## CONCLUSION.

Confident of the experience and care built into the Shorrock supercharger, we wish you many thousand miles of enjoyable motoring from the much improved performance of your car.

Keep these instructions for reference. In any correspondence quote supercharger specification and serial number.

C 75 B

No. 2482



Member of the Owen Organisation

**SHORROCK SUPERCHARGERS LIMITED**  
CHURCH STREET,  
WEDNESBURY,  
STAFFS.

TELEPHONE: WEDNESBURY 1764.